

nieuw

wolcraft®

Modulair werkplaatssysteem



**De werkplaats
naar keus !**

Garantie
guarantee
de garantie
de garantía

10

Jahre
year
años
años

**MADE IN
EUROPE**



wolcraft - modulair werkplaatssysteem



Wilt u eindelijk orde hebben in uw werkplaats?

U wilt u goed voelen in deze werkplaats?















Heeft u ooit gedroomd van een werkplaats waar ergonomisch en praktisch werken mogelijk is?

Het wolcraft modulair werkplaatssysteem biedt u al deze mogelijkheden.

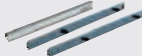
Met een ordelijke en ergonomische werkplaats naar uw behoeften!

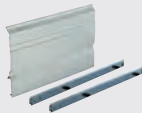

Uw inkooplijst

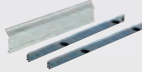
Dell-Nr.	Art-Nr.	Massa	Dell-Nr.	Art-Nr.	Massa
1	 6031 000		9	 6058 000	
2	 6047 000		10	 6039 000	
3	 6043 000		11	 6059 000	
4	 6048 000		12	 6052 000	
5	 6044 000		13	 6057 000	
6	 6049 000		14	 6053 000	
7	 6045 000		15	 6056 000	
8	 6034 000		16	 6055 000	

Uw inkooplijst

Dell-Nr.	Art-Nr.	Massa	Dell-Nr.	Art-Nr.	Massa
17	 6060 000		24	 6067 000	
18	 6076 000		25	 6066 000	
19	 6077 000		26	 6068 000	
20	 6054 000		27	 6074 000	
21	 6065 000		28	 6075 000	
22	 6071 000		29	 6042 000	
23	 6072 000		30	 6046 000	

Het systeem - de voordelen

1. **Modulair** : vrije samenstelling van de werkbank uit individuele componenten
2. **Georganiseerd** : meer dan 100 individuele combinaties dekken alle behoeftes
3. **Evolutief** : de werkbank kan op elk gewenst moment (ook later!) aan nieuwe behoeftes worden aangepast (verhuis, nieuwe vaardigheden, enz.)



4. **Aanpassing** : de behoeftes van zowel links- en rechtshandigen worden hier voldaan.
5. **Met afneembare bankschroef** : dank snelwisselsysteem voor een maximale werkplaats.
6. **Toegang tot uitgebreid werkplaatsysteem**, dwz. dat alle onderdelen ideaal passen en onder elkaar perfect compatibel zijn. Functies, die door geen andere leverancier in deze combinatie worden aangeboden

De werkplaats naar keus!



Het systeem - de voordelen

De werkbanken bestaan uitsluitend uit hoogwaardige componenten :



Stabiele professionele werkbank

- Voeten van stabiele vierkantbuizen 40 x 40 mm
- Alle stalen onderdelen van 1,5 - 2 mm dik staal
- Max. belastbaarheid: 600 kg



Vrije keus van inrichting, vorm en afmetingen van de werkplaats!

De werkbank - produktvoordelen



Soepel lopende schuiflades

- Max. belastbaarheid: 25 kg
- Zeer robuust composiet polyproyleen materiaal
- **Snel uitneembare lades**
- Schuiflade met kogellager systeem

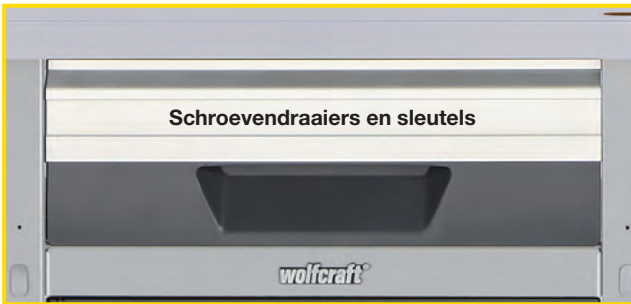

Hoogwaardige aluminium stroken

- met etikettenhouder voor meer orde



Snelmontage-System

- De **werkbankplaten** zijn reeds **voorgeboord**
- De **moeren** zijn **voorgemonteerd** en ingebouwd

Het produkt en zijn functies

Werkoppervlak

3

- **beuk:**

- de traditionele werkplaat
- afschuurbaar en daarom extreem duurzaam
- 30 mm sterk

5

7



Ideale ergonomie door flexibel ontwerp van de voeten

- **Werkhoogte aanpasbaar** middels opsteekbare voeten: Basishoogte: 80 cm
- Hoogte met opsteekbare voeten: 86, 93, 100 cm

Optie: wielen met remmen of in hoogte verstelbare voeten voor onregelmatige vloer.

25



26

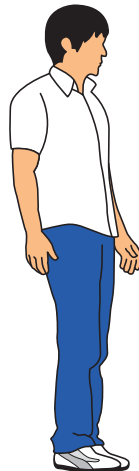
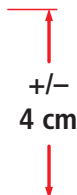

Voor elke lichaamsgrootte de juiste werkhoogte!

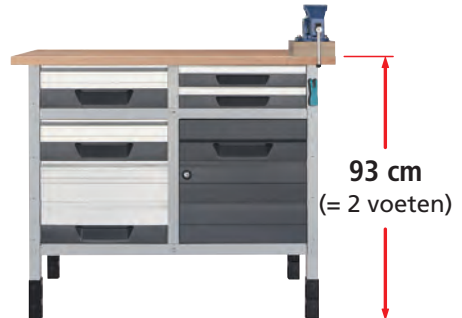

Het produkt en zijn functies

Snelwisselsysteem

Een vlak werkoppervlak en een geïntegreerde bankschroef of boorstandaard sluiten elkaar niet uit!

- **veilige en stabiele bevestiging van stationaire gereedschappen** zoals bv. bankschroef of boorstandaard
- **Snel afgebouwd** dankzij het snelwisselsysteem voor een maximale werkplaats



21

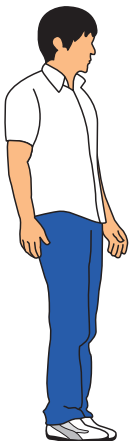

Het ordesysteem

Standaard schuiflades (M) voor b.v. koffers met boren en schroeven*



Hoogte: 14 cm

14 + 16

Hoge lades (L) voor de professionele opslag van machines



Hoogte: 28 cm

14 + 15



*Indeling van lades apart verkrijgbaar

Het ordesysteem

Lage lades (S) voor bv.
moersleutels*



Hoogte: 7 cm

12 + 13

Kast met afsluitbare deur.
Mogelijkheid voor het plaatsen van
drie selecteerbare planken



17 + 18

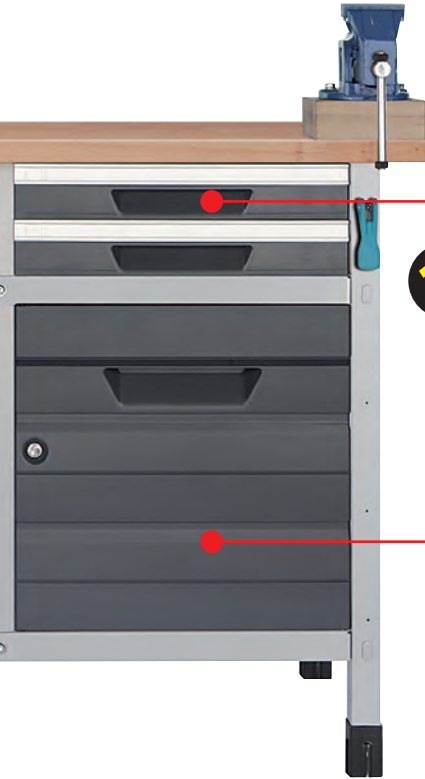

De mobiele oplossingen voor uw project

Perfekte opslag in der werkbank



Gemakkelijk te verwijderen



Buiten de werkbank kunnen de lades afgesloten worden met een deksel ...



... of worden gestapeld

Indeling voor lades apart verkrijgbaar

22

23

Hier een klein uittreksel:

1. Werkbank (65 cm breed):



2. Werkbank (113 cm breed):



3. Werkbank (161 cm breed):



Werkbank configureren: kies het formaat

1. Stap

Kies één of meerdere basis-werkbank(en)



Werkbankbreedte 65 cm
(1 module)

Volledig
uitgebreide
werkbanken
Kies uw modules
op pagina 14

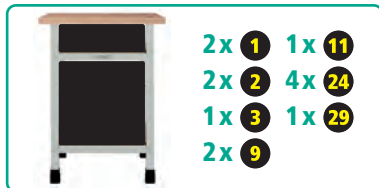

*Werkbanken met
schuifladeplaats
boven en
opslagrek
beneden

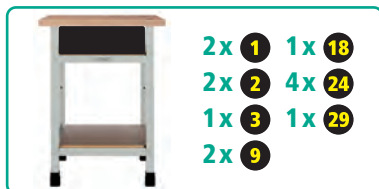

*Werkbanken
met opslagrek
boven en
opslagplaats
beneden

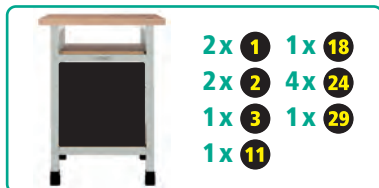

*Werkbanken
met opslagrekken

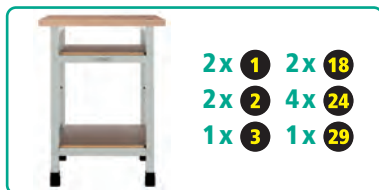

*Kies uw modules op pagina 15

Werkbank configureren: kies het formaat

Werkbankbreedte 113 cm (2 modules)

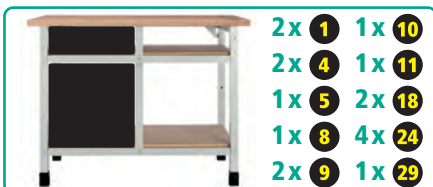
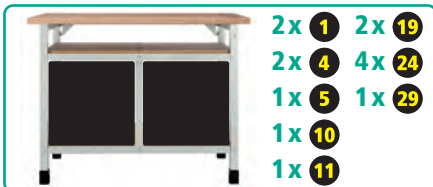
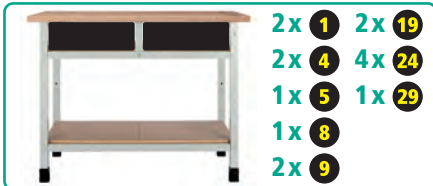
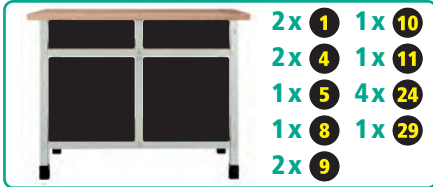

Werkbankbreedte 161 cm (3 modules)



Kies een module voor de inrichting van de basiswerkbank

2. Stap

Stel de voor uw werkbank nodige modules samen uit volgende elementen

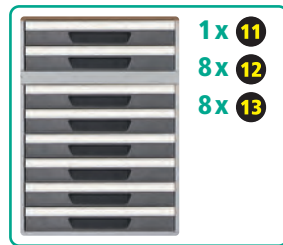
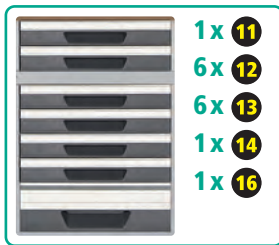
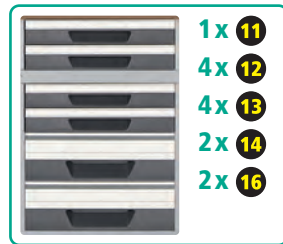
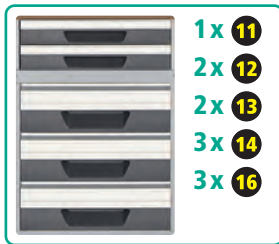
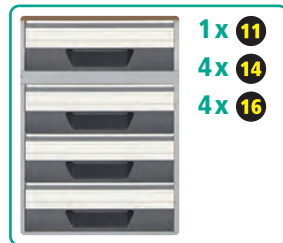

Kies een module voor de inrichting van de basiswerkbank

2. Stap

Stel de voor uw werkbank nodige modules individueel uit de elementen samen :

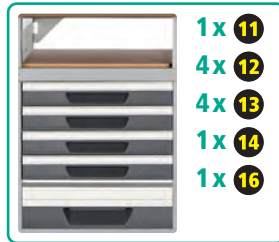
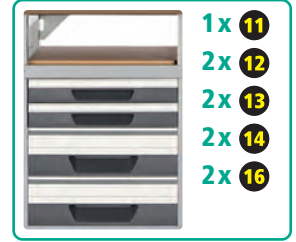
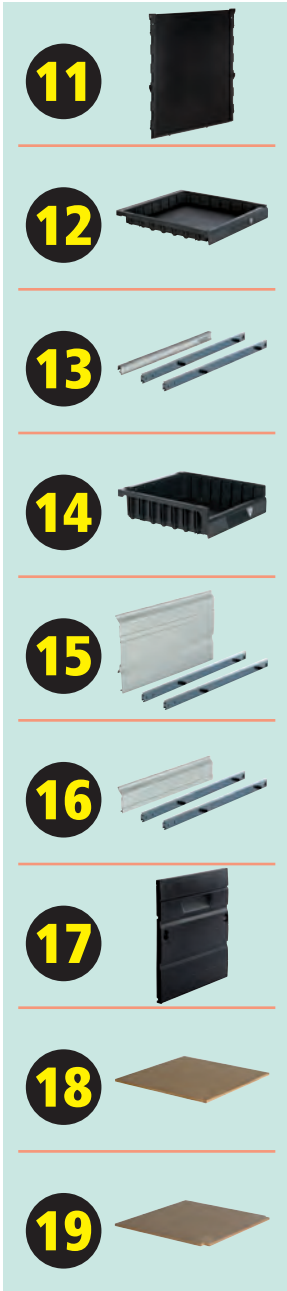

Opties - flexibel ontwerp van de voeten

Voor elke lichaamsgrootte de gepaste werkhoogte!









Individuele keus van de hoogte door de opsteekbare voeten: 80, 86, 93, 100 cm

Kies voor elke voet

1



:

80 cm	Standaardhoogte van 1  Art.nr. 6031000	
Hoogte	Stationair	Mobiel
86 cm	2x 24 	2x 25 
93 cm	4x 24 	2x 24  + 2x 25 
100 cm	6x 24 	4x 24  + 2x 25 

U heeft een oneffen vloer?

Wissel één van de voeten tegen één in de hoogte verstelbare voet.

Zo kunt u een hoogteverschil compenseren tot 4 cm!

1x 26

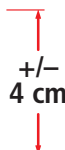

Voorbeeld:

Om de hierboven getoonde werkbank op een hoogte van 93 cm te krijgen heeft u

8x 24



(2 voeten x 4 stuks) nodig

Om een hoogteverstelling te verkrijgen, moet u het aantal op 7 x verminderen

1x 26



en neem :



6065 000 Snelwisselsysteem

- adapter voor het opnemen van stationaire apparaten zoals boorstandaard / bankschroef enz.
- voor een snelle montage en demontage
- de bankschroef wordt middels een excentrische hendel bevestigd



Levering zonder bankschroef of toebehoren

6074 000 Muurbeugelset

- voor een bijkomende fixatie van de werkbank aan de muur
- voor een maximale stabiliteit

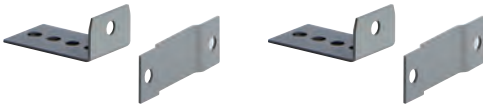

6071/72 000 Onderverdeling lades

- 6071 000 voor Box S (6052 000)
- 6072 000 voor Box M (6053 000)
- inclusief 2 scheidingswanden

22 + **23**

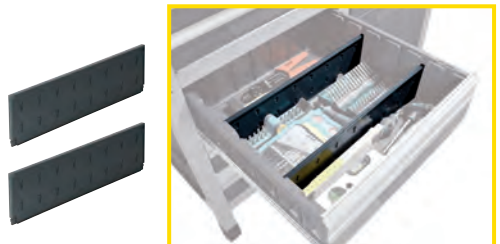

Werkbank uitbreiden

U kunt uw basiswerkbank altijd uitbreiden naar wens.

Hoe gemakkelijk dit is ziet u hier:



Nu staan weer alle modules van bladzijde 14 ter beschikking voor der verdere uitbreiding.



U kunt uw werkbank natuurlijk ook uitbreiden met de hulp van de dwarsdragers 92 cm of 141 cm.

Door de vele mogelijkheden is het dan ook nodig dat u de werkplaat naar uw maatwensen laat snijden.

Voor een glatte overgang van de werkplaten raden wij u het gebruik aan van de metalen verbindingsplaten.

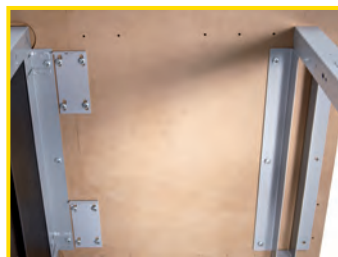
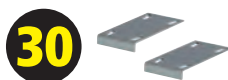

Notities

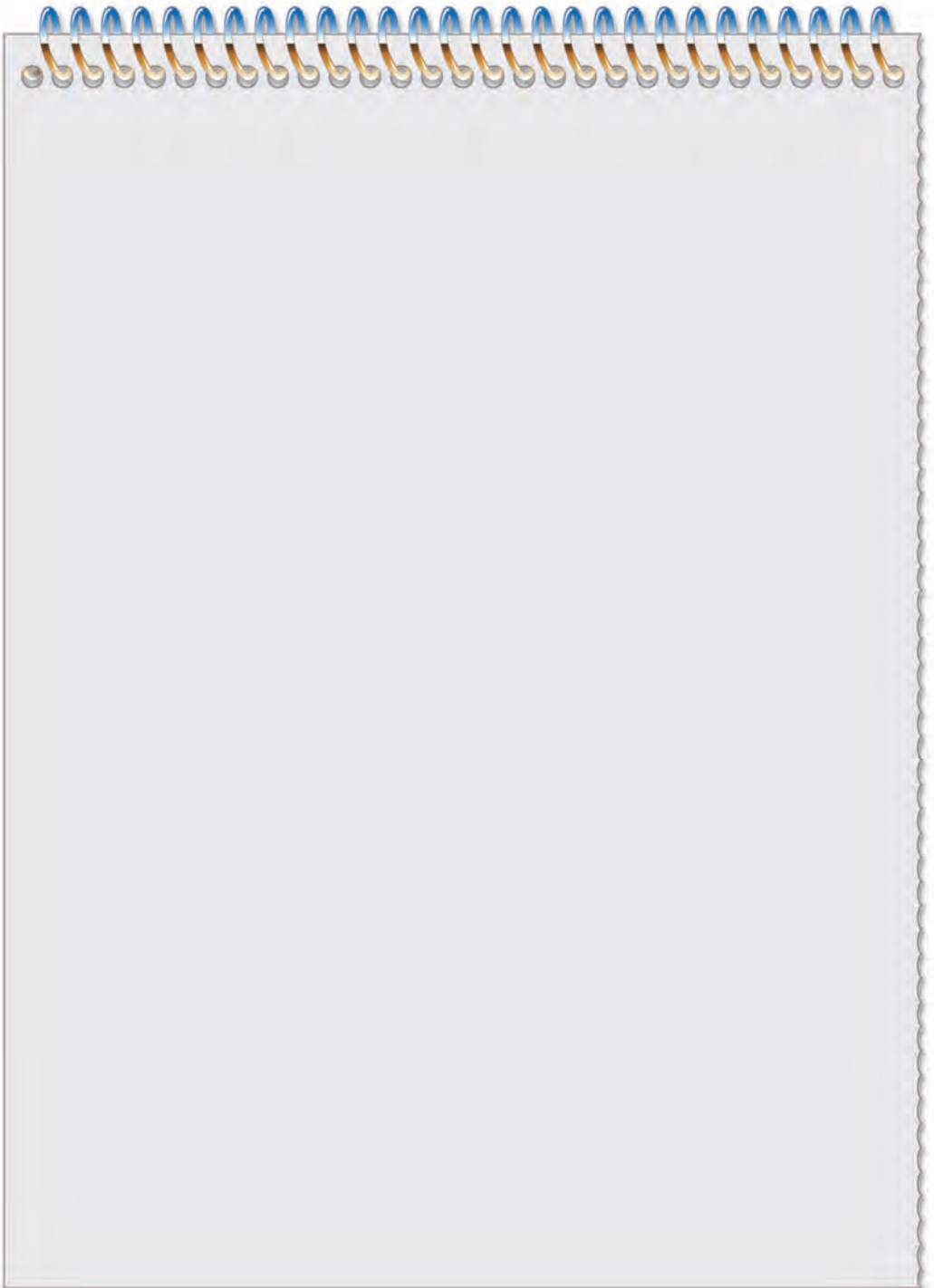

wolfcraft GmbH • Wolff-Straße • 56746 Kempenich • Deutschland
Tel. Belux: +49 2655 51 482 • Fax Belux: +49 2655 502 482
e-mail: customerbelux@wolfcraft.com • Web: www.wolfcraft.com